

Description

APAC QSFP28 transceiver modules are designed for use in 100 Gigabit Ethernet links on up to 30 km of single mode fiber .Digital diagnostics functions are available via the I2C interface, as specified by the QSFP28 MSA.

Features

- Hot-pluggable QSFP28 form factor
- Power dissipation < 4.5W
- Single 3.3V power supply
- RoHS Compliant
- Case temperature range of 0°C to +70°C
- 4x25 Gb/s transmitter
- 4x25G retimed electrical interface
- Duplex LC receptacles
- I2C management interface
- Up to 30km reach for G.652 SMF without FEC
- Up to 40km reach for G.652 SMF with FEC

Application

- 100G Ethernet
- Data Center Interconnects

Ordering information

PART NUMBER	DISTANCE	TEMPERATURE	NOTE
LS3C-L3L-TC-N	30 km	0°C to 70 °C	4X25Gbps



QSFP28 100GBASE-ER4 Lite Transceiver

1310nm LAN WDM for up to 30km reach

Absolute Maximum Ratings

Not necessarily applied together. Exceeding these values may cause permanent damage. Functional operation under these conditions is not implied.

PARAMETER	SYMBOL	MIN	MAX	UNITS	NOTE
Storage Temperature	T _s	-40	85	°C	
Power Supply Voltage	V _{cc}	-0.5	3.6	V	
Relative Humidity	RH	5	85	%	

Recommend Operating Condition

PARAMETER	SYMBOL	MIN	TYP.	MAX	UNITS	NOTE
Case Temperature	T _c	0		70	°C	
Power Supply Voltage	V _{cc}	3.14	3.3	3.46	V	
Power Dissipation				4.5	W	@3.3V



QSFP28 100GBASE-ER4 Lite Transceiver

1310nm LAN WDM for up to 30km reach

Transmitter Optical Characteristics

PARAMETER	SYMBOL	MIN	TYP.	MAX	UNITS	NOTE
L						
Operating Data Rate	<i>DR</i>		25.78125		Gbps	
Total Average Launch Power	<i>P_t</i>			10.5	dBm	
Average Launch Power, per lane		-2.9		4.5	dBm	
Extinction Ratio	<i>ER</i>	7			dB	
Optical Modulation Amplitude, per lane	<i>P_{oma}</i>	0.1		4.5	dBm	
Difference in Launch Power between any Two Lanes (OMA)	<i>P_{tx, diff}</i>			3.6	dBm	
Launch Power in OMA minus Transmitter and Dispersion Penalty (TDP), per lane		-0.65			dBm	
Transmitter Dispersion Penalty, per lane	<i>TDP</i>			2.5	dB	
Center Wavelength	<i>L0</i>	1294.53	1295.56	1296.59	nm	
	<i>L1</i>	1299.02	1300.05	1301.09	nm	
	<i>L2</i>	1303.54	1304.58	1305.63	nm	
	<i>L3</i>	1308.09	1309.14	1310.19	nm	
Side Mode Suppression	<i>SMSR</i>	30			dB	
RIN _{20OMA}	<i>RIN</i>			-130	dB/Hz	
Optical Return Loss Tolerance	<i>TOL</i>			20	dB	
Transmitter Reflectance	<i>RT</i>			-12	dB	
Disable Output Power	<i>P_{o_off}</i>			-30	dBm	
Output Eye Mask Definition {X1, X2, X3, Y1, Y2, Y3}			{0.25, 0.4, 0.45, 0.25, 0.28, 0.4}			



QSFP28 100GBASE-ER4 Lite Transceiver

1310nm LAN WDM for up to 30km reach

Receiver Optical characteristics

PARAMETER	SYMBOL	MIN	TYP.	MAX	UNITS	NOTE
Damage Threshold, per lane	<i>Pth</i>	-3			dBm	
Average Receive Power, per lane		-20		-5	dBm	
Receive Power (OMA), per lane				-5	dBm	
Receiver Sensitivity(OMA), per lane	<i>Sen1</i>			-14.7	dBm	
Stressed Receiver Sensitivity in OMA, per lane				-12.7	dBm	BER = 1X10 ⁻¹²
Receiver Sensitivity(OMA), per lane	<i>Sen2</i>			-18.7	dBm	
Stressed Receiver Sensitivity in OMA, per lane				-16.7	dBm	BER = 5X10 ⁻⁵
Receiver reflectance	<i>RR</i>			-26.0	dB	
Difference in Receive Power between any Two Lanes (OMA)	<i>Prx, diff</i>			3.6	dB	
Receiver Electrical 3dB upper Cutoff Frequency, per lane	<i>Fc</i>			31	GHz	
LOS De-Assert	<i>LOSD</i>			-20	dBm	
LOS Assert	<i>LOSA</i>	-35			dBm	
LOS Hysteresis		0.5			dB	
Vertical Eye Closure Penalty, per lane			1.5		dB	
Stressed Eye J2 Jitter, per lane			0.3		UI	
Stressed Eye J9 Jitter, per lane			0.47		UI	

Electrical Characteristics

PARAMETER	SYMBOL	MIN	TYP.	MAX	UNITS	NOTE
Data Rate, per lane			25.78125		Gbps	
LP Mode/Reset/ModselL	VIL	-0.3		0.8	V	
LP Mode/Reset/ModselL	VIH	2		V _{cc} +0.3	V	
ModPrsL/IntL	VOL	0		0.4	V	
ModPrsL/IntL	VOH	V _{cc} -0.5		V _{cc} +0.3	V	

Pad assignment and Description

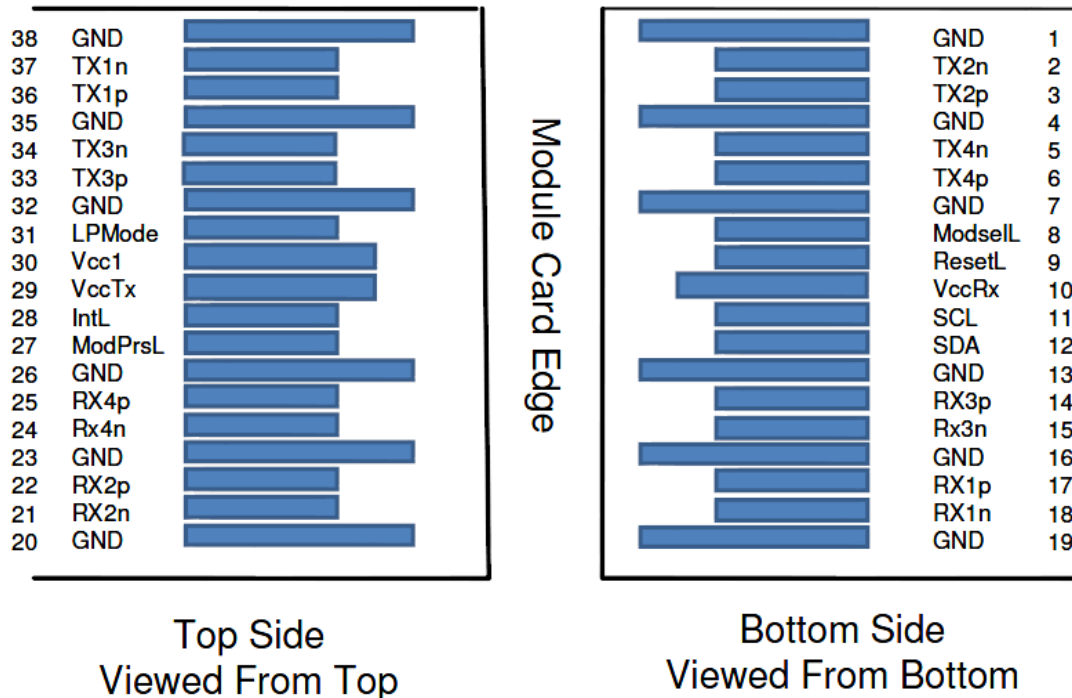

PIN	LOGIC	SYMBOL	DESCRIPTION	PLUG SEQUENCE	NOTE
1		GND	Ground	1	Note 1
2	CML-I	Tx2n	Transmitter Inverted Data Input	3	
3	CML-I	Tx2p	Transmitter Non-Inverted Data Input	3	
4		GND	Ground	1	Note 1
5	CML-I	Tx4n	Transmitter Inverted Data Input	3	
6	CML-I	Tx4p	Transmitter Non-Inverted Data Input	3	
7		GND	Ground	1	Note 1
8	LVTTL-I	ModSelL	Module Select	3	
9	LVTTL-I	ResetL	Module Reset	3	
10		Vcc Rx	+3.3V Power Supply Receiver	2	Note 2
11	LVC MOS-I/O	SCL	2-wire serial interface clock	3	
12	LVC MOS-I/O	SDA	2-wire serial interface data	3	
13		GND	Ground	1	Note 2
14	CML-O	Rx3p	Receiver Non- Inverted Data Output	3	
15	CML-O	Rx3n	Receiver Inverted Data Output	3	
16		GND	Ground	1	Note 1
17	CML-O	Rx1p	Receiver Non- Inverted Data Output	3	
18	CML-O	Rx1n	Receiver Inverted Data Output	3	
19		GND	Ground	1	Note 1
20		GND	Ground	1	Note 1



QSFP28 100GBASE-ER4 Lite Transceiver

1310nm LAN WDM for up to 30km reach

21	CML-O	Rx2n	Receiver Inverted Data Output	3	
22	CML-O	Rx2P	Receiver Non- Inverted Data Output	3	
23		GND	Ground	1	Note 1
24	CML-O	Rx4n	Receiver Inverted Data Output	3	
25	CML-O	Rx4p	Receiver Non- Inverted Data Output	3	
26		GND	Ground	1	Note 1
27	LVTTL-O	ModPrsL	Module Present	3	
28	LVTTL-O	IntL	Interrupt	3	
29	LVC MOS-I/O	Vcc Tx	+3.3V Power Supply transmitter	2	Note 2
30		Vcc1	+3.3V Power Supply	2	Note 2
31	LVTTL-I	LPMode	Low Power Mode	3	
32		GND	Ground	1	Note 1
33	CML-I	Tx3p	Transmitter Non- Inverted Data Input	3	
34	CML-I	Tx3n	Transmitter Inverted Data Input	3	
35		GND	Ground	1	Note 1
36	CML-I	Tx1p	Transmitter Non- Inverted Data Input	3	
37	CML-I	Tx1n	Transmitter Inverted Data Input	3	
38		GND	Ground	1	Note 1

Note 1: GND is the symbol for signal and supply (power) common for the QSFP module. All are common within the QSFP+ module and all module voltages are referenced to this potential unless otherwise noted. Connect these directly to the host board signal-common ground plane.

Note 2: Vcc Rx, Vcc1 and Vcc Tx are the receiver and transmitter power supplies and shall be applied concurrently. Requirements defined for the host side of the Host Edge Card Connector are listed in Table. Recommended host board power supply filtering is shown in Host board power supply circuit. Vcc Rx Vcc1 and Vcc Tx may be internally connected within the QSFP module in any combination. The connector pins are each rated for a maximum current of 500 mA.

Host board power supply circuit

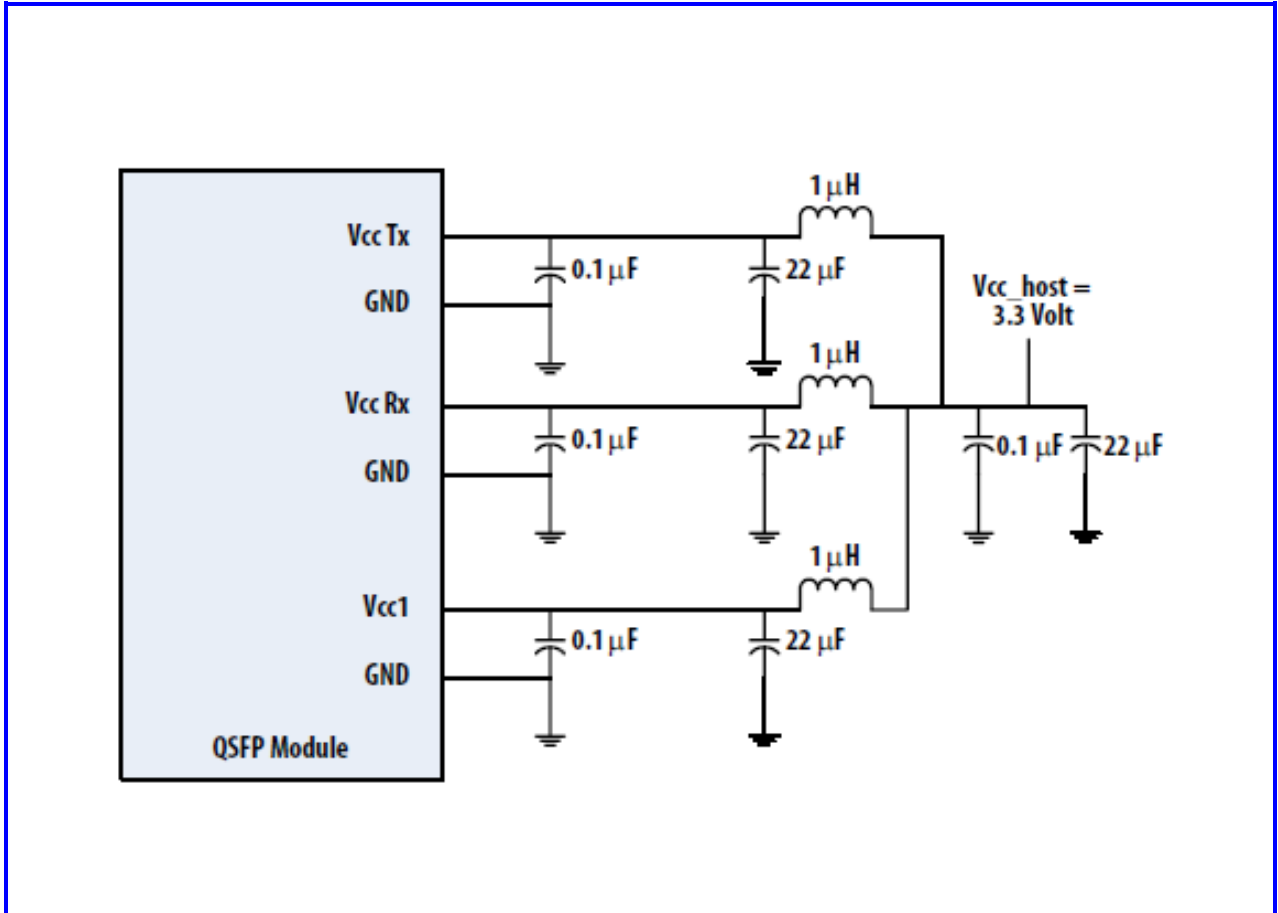

Recommended Interface circuit

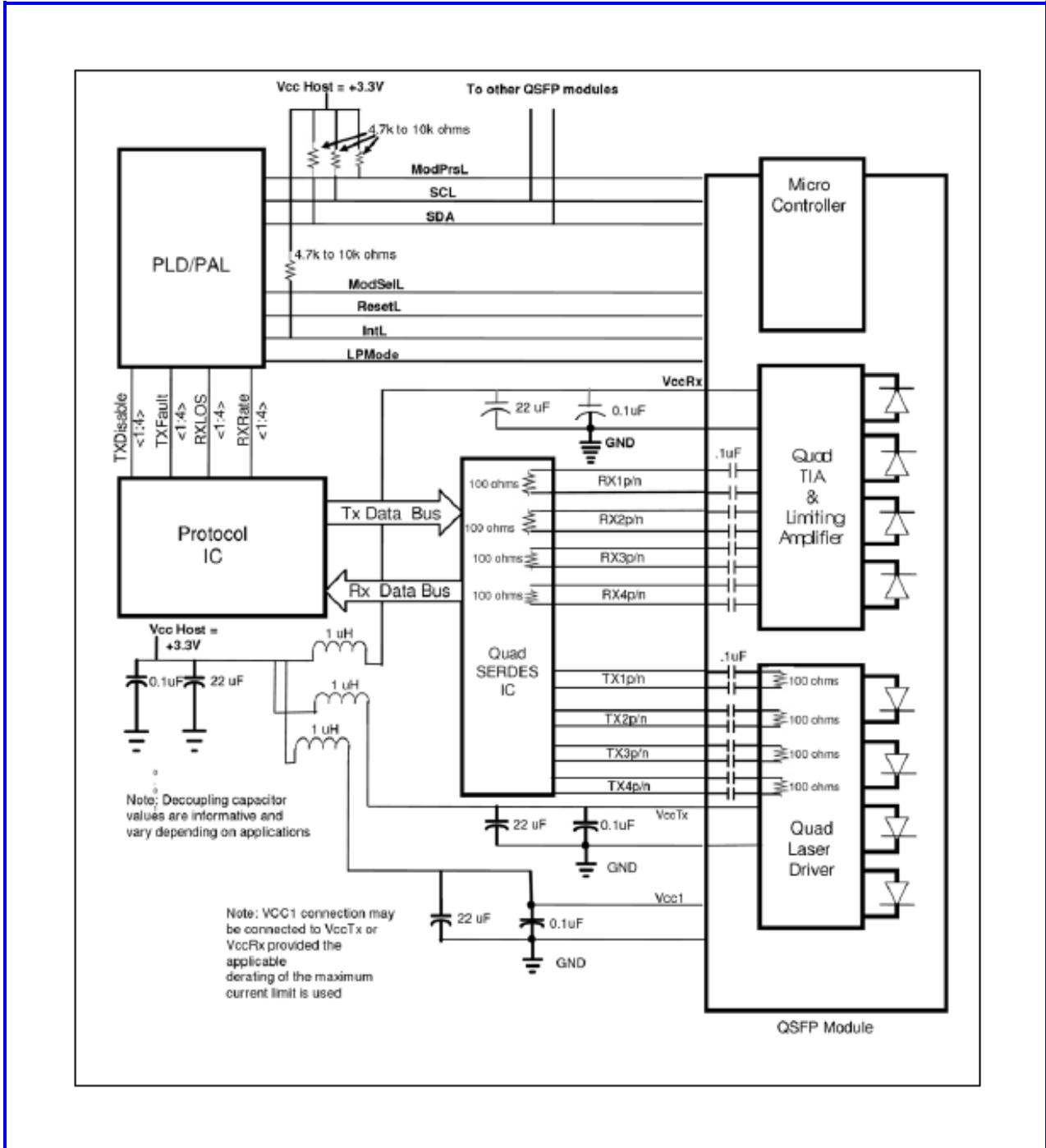

Dimensions

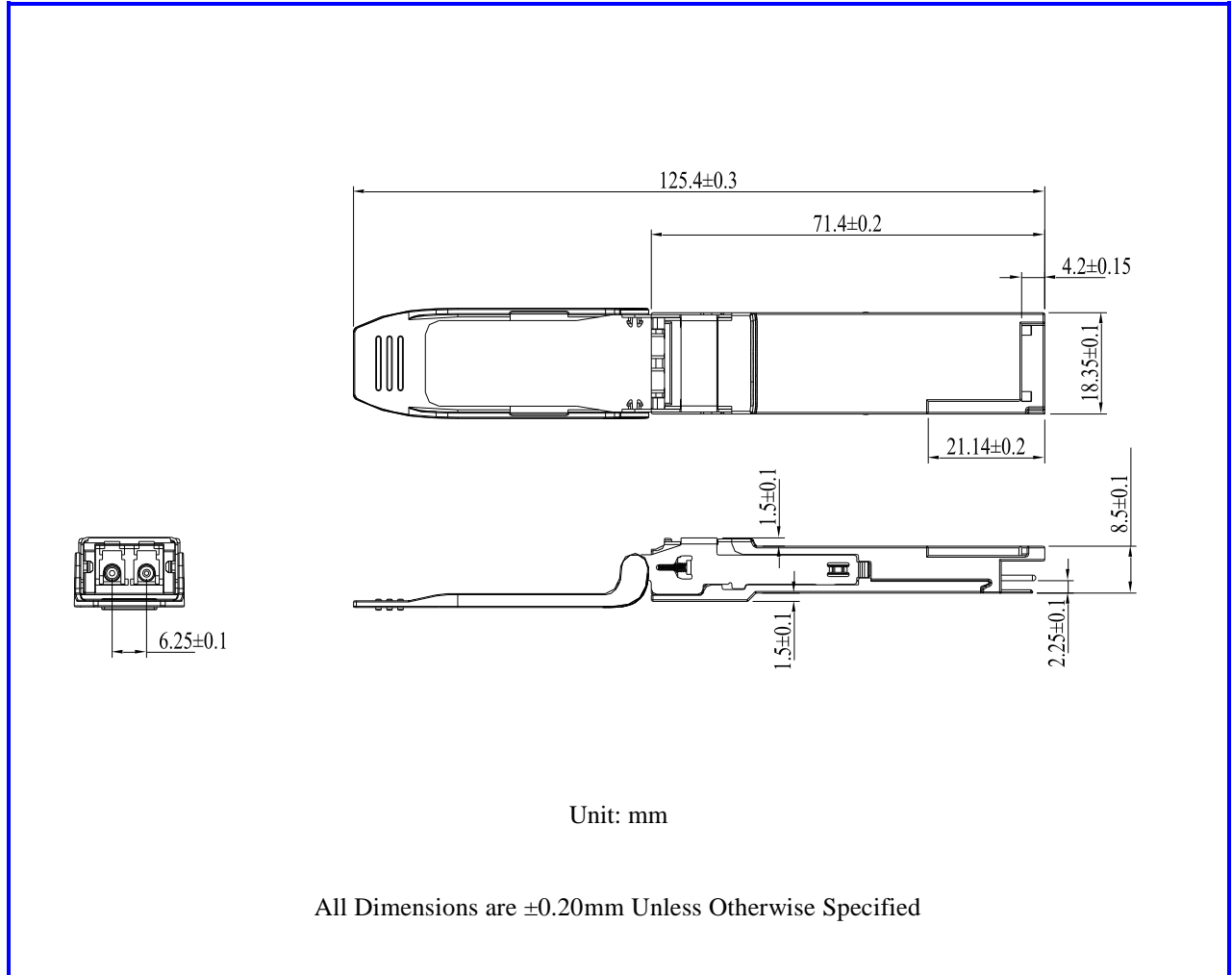



QSFP28 100GBASE-ER4 Lite Transceiver

1310nm LAN WDM for up to 30km reach

Memory Map

